

MIGATRONIC ACCESSORIES



MIGATRONIC



Have you chosen the right accessories?

4 - 15	Personal safety
16 - 18	Pressure regulators
19	Remote controls
19	Chemicals
20	Tools
21	Fume extraction
22- 25	Automotive equipment
26- 27	Quick release fittings
28 - 30	Cables/plugs and holders
31	Electrode ovens

Personal safety

Migatronic personal safety products have been produced specifically for the welding industry and are marked, tested, and subsequently approved according to accepted standards. All of Migatronic's personal safety products carry CE qualification.

Pressure regulators

Migatronic offers a new and complete range of pressure regulators. Migatronic pressure regulators in the 200 range cover all requirements, and the incorporation of a gas saver regulator will allow you to save up to 60% of your gas consumption.

Protector welding helmets

The Migatronic Protector welding helmets are made of lightweight and robust materials using advanced moulding techniques. The design provides optimum protection of the welder's head, chin and ears.

Automotive equipment

Since its establishment back in 1970, Migatronic has been engaged in optimising welding equipment for the automotive trade. More than 40 years' experience that we would like to share with you.

Range of accessories

Should you not find the required item in this catalogue, please contact Migatronic.



Personal safety



Welding gloves TIG
Welding gloves in a soft quality with a 14 cm cuff in split leather sewn with Kevlar. Perfect for quality welding. Size 9 and 10
9: Article no.81930023
10: Article no.81930024



Welding gloves TIG
TIG welding gloves in a soft quality; cuffs in cowhide; sewn with Kevlar; sizes 9/10/11.
9: Article no.81930025
10: Article no.81930026
11: Article no.81930027



Welding gloves MIG/MAG
Luxury MIG/MAG welding gloves. Very comfortable and soft heat-resistant leather gloves with internal Kevlar stitching.
Article no.81930038



Welding gloves
Strong welding gloves made of cowhide. Upper side of split leather and index finger of hide. Size 11.
Article no.81930034



Welding gloves MIG/MAG
Welding gloves in a soft quality; top side and cuffs in cowhide; sewn with Kevlar; unlined; size 10.
Article no.81930033



Welding/cutting goggles
Welding/cutting goggles with side protection and leather head strap.
DIN 6:
Article no.81912305



Welding/grinding goggles *
Combined welding/grinding goggles with round carborock glass. Fixed grinding goggles and flip-up welding goggles. Glasses can be changed as required.
Article no.81912005



Welding/grinding goggles
Sleek, sporty style goggles providing 99.9% protection against the damaging UV radiation. Comfortable to wear owing to soft-touch temples and lightweight construction. Full range of vision.
Clear
Article no.81912017
Umber
Article no.81912018
Tinted mirror
Article no.81912019
DIN 3
Article no.81912020
DIN 5
Article no.81912021



Skirt apron
Skirt apron in split leather with riveted nylon strap and click buckle.
Length 500 mm, width 580 mm.
Article no.81930018



Welding apron
Welding apron in split leather with riveted nylon strap and click buckle.
Length 900 mm, width 580 mm.
Article no.81930015



Welding jacket
Lightweight, protective welding jacket in fire-resistant fabric. Designed specifically for the welding industry. One-size.
Article no.81930043



Sleeves
Lightweight set of sleeves with elastic and buttons for shoulder fixing. Protects against grinding particles and weld spatter.
Article no.81930040



Welding mat
Leather and split leather.
Length 520 mm, width 330 mm.
Article no.81930010



Grinding shield
Standard grinding shield with pivot fittings in headband.
Article no.81910007
Visor for grinding shield
Article no.81910008



Sweat frontlet
Sweat frontlet of imitation leather for fixing on headband. Sets of two.
Article no.81910119



Leggings
Legging in split leather with Velcro fastening. Sets of two.
Article no.81930036



Welding hood
Welding hood in split leather for protection of head and back of the head during welding.
Article no.81910117



Welding hood
Welding hood in fire-resistant fabric for protection of head, neck and shoulders against weld spatter, grinding particles and radiation.
Article no.81930042



Neck protection
Neck protection designed specifically for Migatronci welding helmet. Protects against weld spatter and radiation.
Article no.81930041



Fiberglass welding helmet
Fiberglass welding helmet with clear glass observation strip. Welding/safety glass 60 x 110 mm. Observation glass 22 x 108 mm
Article no.81910001
Headband for welding helmet
Article no.81910100



Polypropylene welding helmet
Polypropylene welding helmet with clear glass observation strip. Welding/safety glass 60 x 110 mm. Observation glass 22 x 108 mm
Article no.81910090
Headband for welding helmet
Article no.81910100



Fiberglass welding helmet *
Fiberglass welding helmet with flip-up frontpiece. Welding/safety glass 60 x 110 mm. Observation glass 64 x 101 mm
Article no.81910180
Headband for welding helmet
Article no.81910100



Handshield
Small green PVC hand shield.
Article no.81910144

* = Special order item

Personal safety



Odour filter *
Eliminates obnoxious smells and tastes.
Article no.81910311

Pre-filter *
Extends life of the main filter.
Article no.81910309



Power filters for welding helmets

- 51 x 108 mm Clear + 1.0 Article no.81911051
- 51 x 108 mm Clear + 1.5 Article no.81911046
- 51 x 108 mm Clear + 2.0 Article no.81911047
- 51 x 108 mm Clear + 2.5 Article no.81911048



Velcro band
For fitting in helmet
Article no.81930050



Green welding helmet
Economy welding helmet with clear glass observation strip.
Article no.81910010
Headband for welding helmet
Article no.81910100



Protector ADF welding helmet
Automatic filter (ADF); external DIN adjustment 9-13; adjustable delay; visual field 42 x 96 mm; adjustable sensitivity; solar battery.
Article no.81910595



Internal protection glass for Protector ADF welding helmet
10 pcs.
Article no.81910591

External protection glass for Protector ADF welding helmet
10 pcs.
Article no.81910107

The Migatronc Protector welding helmets are made of lightweight and robust materials using advanced moulding techniques. The designs provide optimum protection of the welder's head, chin and ears. The ergonomically-correct fit makes the welding helmet comfortable to wear and allows a free supply of fresh air.



Cool EI 1 (Basic 2000 Flow Control) *
Fully motorised respiratory protection system, approved according to EN12941: 1999. Supplied complete with P3 particle filter (see photo) and microcomputer allowing the welder to keep a constant pressure regardless of the size of battery or how much the filter is clogged up. If the pressure falls to below 140 l/min., an acoustic alarm will sound. Pressure is adjustable in 8 steps from 160 to 210 l/min. The microcomputer also allows the welder to check the capacity of battery and filter.

- Cool EI 1 is available with the following types of helmets:
- Protector 501 Article no.81910564
 - Protector 501 TM Article no.81910566
 - Protector 551 Article no.81910565

Helmet
incl. air duct, face seal and headband, excl. filter.
Article no.81910561



Face shield *
Face shield with acetate visor top.
Article no.81910336



Air diffuser *
Air diffuser for fitting on headband. Identical for models Cool EI 1 and Cool EI 2.
Article no.81910213



Basic 2000 Flow Control *
Article no.81910317



Face seal
Identical for models 1 and 2.
Article no.81910319



Fresh air hose *
Separate flexible hose for models Cool EI 1 and 2.
Article no.81910275



Separate belt *
Identical for models 1, 2 and Cool Compressed Air.
Article no.81910315



Spare visor with Velcro *
Article no.81910337



Particle filter P3
Highly efficient filter protecting against dust particles as well as solid and liquid aerosols.
Article no.81910310



Battery *
NiMh 4.0 V/4.5 Ah
Operation time 6-15 hours
Duration of charge 10-15 hours
Life min. 500 recharges.
Article no.81910318



Charger *
Charger with timer, 14 hours-plug charger NiCol and NiMh batteries. Input 230 V/50 Hz 9w. Output 5.6 V/500 Ma/2.8 Va.
Article no.81910292

* = Special order item



Filters for Cool EI 2 (Chemical Flow Control)



Combination filters
A2P3-EN141-TH2/TH3 APSL
EN12941. Protects against dust particles, solid and liquid aerosols and chemical gases according to the filter guide page 12. **Ozone approved.**
Article no.81910324

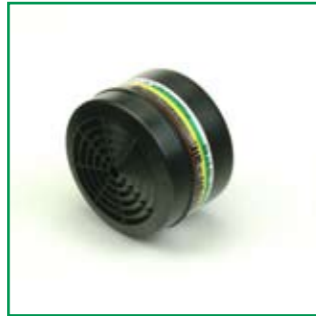

Combination filters *
A2B3E2K2P3-EN141-TH2/TH3 ABEKPSL EN12941. Protects against dust particles, solid and liquid aerosols and chemical gases according to the filter guide page 12.
Article no.81910325



Gas filter *
A2-EN141-TH2/TH3 A EN12941. Protects against chemical gases according to filter guide page 12.
Article no.81910323



Particle filter *
P3-EN143-TH2/TH3 PSL EN12941. Protects against dust particles, solid and liquid aerosols according to filter guide page 12.
Article no.81910215



Cool EI 2 (Chemical Flow Control)

Fully motorised respiratory protection system, approved according to EN 12941: 1999. Supplied complete with P3 particle filter (see photo) and microcomputer changing the air current in the motor to constant 160 l/min. If the filter is clogged up or the battery falls to a low level, the welder is warned by a visual and acoustic alarm.

Cool EI 2 is available with the following types of helmets:

- | | |
|--------------------------|--------------------------|
| Protector 501 | Protector 501 TM |
| Article no.81910569 | Article no.81910571 |
| Protector 551 | |
| Article no.81910570 | |



Face shield *
Face shield with acetate visor top.
Article no.81910336



Chemical Flow Control *
Article no.81910320



Charger *
Charger NiCd 8 NiMh 4-10 cells. Input 230 V/50 Hz. Output 7.2 V/max 600 Ma.
Article no.81910322



Battery *
NiMh 6V/4.5 Ah
Operation time 6-10 hours
Duration of charge 10-14 hours
Life min. 500 recharges.
Article no.81910321



Cool Compressed air

Unit supplied complete with belt with valve, fresh-air hose, welding helmet with built-in air-duct and face seal. The unit is available with the following types of helmets:

- | | |
|--------------------------|--------------------------|
| Protector 501 | Protector 501 TM |
| Article no.81910574 | Article no.81910576 |
| Protector 551 | |
| Article no.81910575 | |

Cool Compressed air grind, article no.: 81910374

Unit supplied with the items shown below: Article nos. 81910326 and 81910336.



Face shield *
Face shield with acetate visor top.
Article no.81910336



Belt with valve
Constant pressure 160 l/min.
Article no.81910326



Air diffuser *
Air diffuser for fitting on headband.
Article no.81910213



Face seal
Identical for models Cool EI 1, Cool EI 2 and Cool Compressed Air.
Article no.81910319



Sweat frontlet
Article no.81910377



Air pre-heater
Luxury model
Article no.81910227



Fresh air hose *
Separate fresh air hose for Cool EI 1, Cool EI 2 and Cool Compressed Air.
Article no.81910275



Separate belt *
Identical for models 1, 2 and Cool Compressed Air.
Article no.81910315

* = Special order item

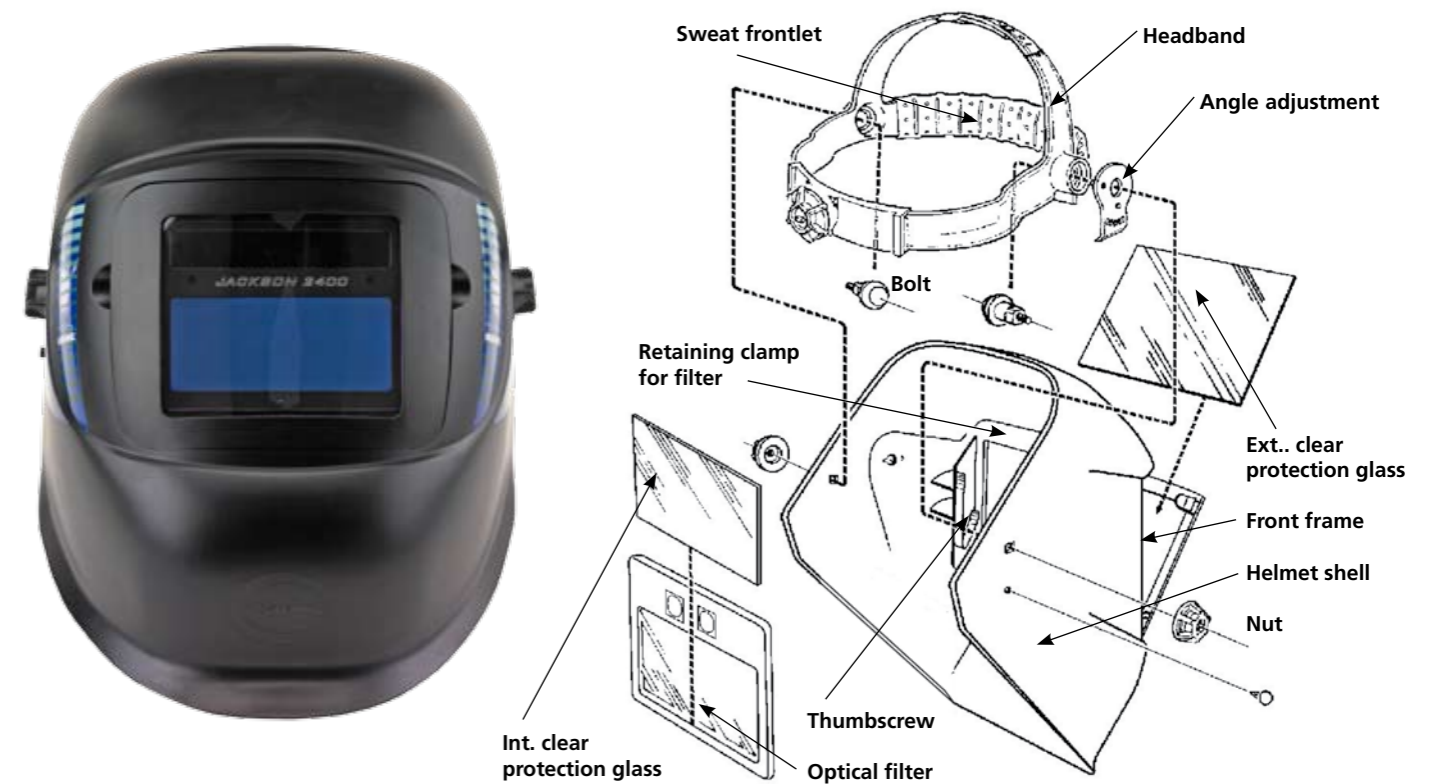
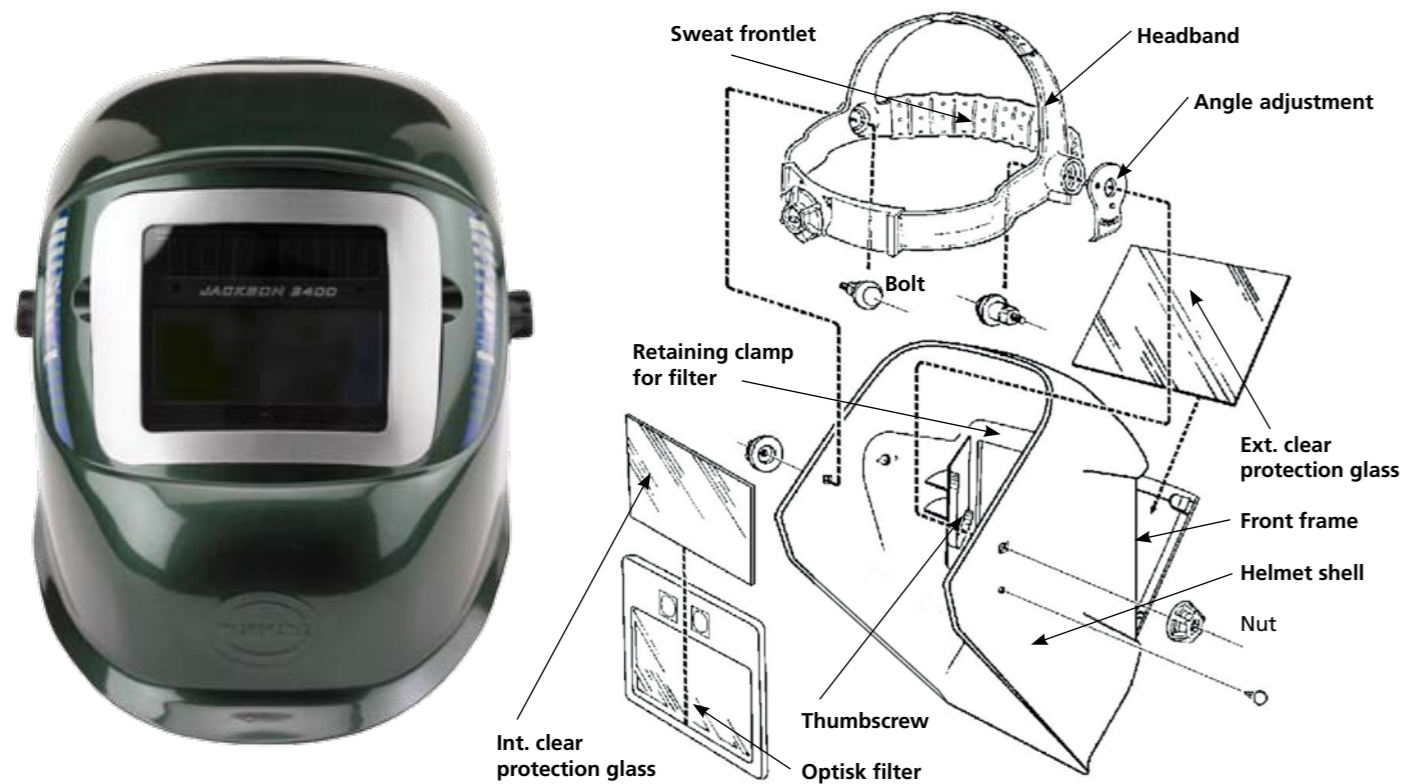

GREEN	Protector 501	Protector 551	Protector 501TM
Article no.	81910556	81910557	81910558 **
Back up	2 x AAA Battery	Solar	2 x AAA Battery
DIN light/dark Ext./Int. adjust.	4-9/12 Interior	4-9/13 Interior	4-9/12 Interior
No. of sensores	2	3	2
Adjustable sensitivity	Manually	Manually	Manually
Post weld delay	0.1-1.0 sec.	0.1-1.0 sec.	0.1-1.0 sec.
Darkening time	0.08ms*	0.4 ms	0.08ms*
Preferred segment	All	All	All
Limitations	None	None	None
Visual field	40 x 97mm	40 x 97mm	62 x 98mm
Weight	440 g	440 g	440 g
Complete helmet without filter	81910548	81910548	81910548
Headband	81910542	81910542	81910542
Sweat frontlet	81910543	81910543	81910543
Front frame	81910577	81910577	81910577
Thumbscrew	81910578	81910578	81910578
Bolt	81910544	81910544	81910544
Angle adjustment	81910546	81910546	81910546
Nut	81910545	81910545	81910545
Ext. protect. glass	81910107	81910107	81910107
Int. protect. glass	81910106	81910106	81910418
Spare optical filter	81910417	81910559	81910420

* = The world's fastest

** = Special order item

BLACK	Protector ADF	Protector 501	Protector 551	Protector 501TM
Article no.	81910595	81910552	81910551	81910553
Back up	Solar	2 x AAA Batteri	Solar	2 x AAA Batteri
DIN light/dark Ext./Int. adjust.	4-9/13 Exterior	4-9/12 Interior	4-9/13 Interior	4-9/12 Interior
No. of sensores	2	2	3	2
Adjustable sensitivity	Manually	Manually	Manually	Manually
Post weld delay	0,1-1,0 sek.	0.1-1.0 sec.	0.1-1.0 sec.	0.1-1.0 sec.
Darkening time	0.4 ms	0.08ms*	0.4 ms	0.08ms*
Preferred segment	All	All	All	All
Limitations	TIG < 20 A	None	None	None
Visual field	41 x 97mm	40 x 97mm	40 x 97mm	62 x 98mm
Weight	440 g	440 g	440 g	440 g
Complete helmet without filter	-	81910547	81910547	81910547
Headband	-	81910542	81910542	81910542
Sweat frontlet	81910119	81910543	81910543	81910543
Front frame	-	81910538	81910538	81910538
Thumbscrew	-	81910578	81910578	81910578
Bolt	-	81910544	81910544	81910544
Angle adjustment	-	81910546	81910546	81910546
Nut	-	81910545	81910545	81910545
Ext. protect. glass	81910107	81910107	81910107	81910107
Int. protect. glass	81910591	81910106	81910106	81910418
Spare optical filter	-	81910417	81910559	81910420

* = The world's fastest



Combination filters (page 8)

Colour code	Letter	Field of application	Cool EI 1	Cool EI 2	Cool Compressed air
White	P	Particles, aerosols	•	•	•
Brown	A	Organic vapours		•	•
Grey	B	Inorganic vapours		•	•
Yellow	E	Sulphur dioxide		•	•
Green	K	Ammonia, organic amines		•	•
Red	Hg	Mercury vapours		•	•
	SL	Liquid aerosols (Solid Liquids)	•	•	•



Electric pre-heater *
Article no.81910332



Wall filter Unit *
Complete wall filter with 2 outlets
Article no.81910330
Complete wall filter with 4 outlets
Article no.81910331
Carbon filter element, 2/4 outlets
Article no.81910333
Oil/water element, 2 outlets
Article no.81910334
Oil/water element, 4 outlets
Article no.81910335



Wall filter Unit - floor rack option *
2 outlets on floor rack
Article no.81910341
4 outlets on floor rack
Article no.81910342
2 outlets on floor rack, pre-heater
Article no.81910343
4 outlets on floor rack, pre-heater
Article no.81910344
Detachable floor rack for wall filter
Article no.81910345



Intermediary hoses *
Intermediary hoses 5 m.
Article no.81910338
Intermediary hoses 10 m.
Article no.81910339

Coupling
Quick-release fitting female 3/8" ext. thread
Article no.81910340
Quick-release fitting male 3/8" ext. thread
Article no.81910346
Quick-release fitting male 1/4" ext. thread
Article no.81910347

Compressed air belt and wall filter unit are supplied without quick releases

* = Special order item

Article no.	Size	Protector One	Protector Two	Protector Three	Protector Four	Protector 4,5	Protector Five 501 - 551	Protector Five Turbo Max. 501TM	Protector Five Exclus.	J.B.O. Argon with observation strip	J.B.O. Argon with flip-up frontpiece	Handshield
81911081 DIN 7	51x108			•						•		•
81911001 DIN 8	51x108			•						•		•
81911007 DIN 9	51x108			•						•		•
81911005 DIN 10	51x108			•						•		•
81911008 DIN 11	51x108			•						•		•
81911006 DIN 12	51x108			•						•		•
81911049 DIN 13	51x108			•						•		•
81911004 Green acrylic	22x108									•		
81911063 Yellow acrylic	22x108									•		
81911082 DIN 7	60x110		•							•	•	
81911060 DIN 8	60x110		•							•	•	
81911059 DIN 9	60x110		•							•	•	
81911058 DIN 10	60x110		•							•	•	
81911057 DIN 11	60x110		•							•	•	
81911056 DIN 12	60x110		•							•	•	
81911055 DIN 13	60x110		•							•	•	
81911045 1000 hours filter	51x108			•						•		•
81911053 1000 hours filter	60x110		•								•	
81911003 Clear acrylic	22x108								•			
81911002 Clear acrylic	51x108							•		•		
81911054 Clear acrylic	60x110		•								•	
81911061 Clear acrylic	64x101									•		
81910401 DIN 9	90x110	•										
81910402 DIN 10	90x110	•										
81910403 DIN 11	90x110	•										
81910404 DIN 12	90x110	•										
81911062 Clear protection glass	90x110	•			•		•	•	•			
81910107 Clear protection glass	97x110	•			•	•	•	•	•			
81910106 Clear protection glass	51x107			•		•	•		•			
81911064 Clear protection glass	25x110		•									
81911065 Clear protection glass	68x110		•									
81910418 Clear protection glass	66x109							•				
81910414 Optical filter DIN 10	90x110				•							
81910417 Optical filter DIN 10-13	90x110						•					
81910420 Optical filter DIN 9-12	90x110							•				

• Old models • New models

If you require DIN filters or clear protection glass in special measurements, please contact Migatronik.

Welders risk exposure to radiation, weld spatter and grinding dust during welding operations. The use of Migatronik shielding products reduces this risk considerably and eliminates radiation damage if the products are used according to instructions.



Warning
Eyesight, one of our most important senses, is easily damaged by UV and IR radiation as well as by the visible blue light from the welding arc. Furthermore, sparks, spatter and metal splinters may get into your eye and cause permanent sight damage.

Standard
Migatronik welding curtains are DIN approved and meet the requirements of:
• EN - 1598
• DIN 21404, del 2

Migatronik welding curtains and strip curtains protect against every kind of UV radiation up to 560 nm.

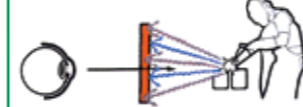

Migatronik welding curtains and strip curtains are transparent and protect the eyes from the damaging light.

Welding curtains

Separate curtains in standard sizes with ring holes at 22 cm spacing at the top and with plastic snap fasteners welded on the sides. Supplied with 7 steel rings. Available as follows:

	Dull green Non-transparent	Orange Transparent	Brown (Bronze) Transparent
Height x width	Article no.	Article no.	Article no.
1600 x 1400 mm	81910158 *	81910155 *	81910152 *
1800 x 1400 mm	81910159 *	81910156 *	81910153 *
2000 x 1400 mm	81910160	81910157	81910154

Build your personal welding booth

Max. distance between floor and curtain: 40 cm

Your personal welding booth can be made of curtains of fixed dimensions, curtains with snap fasteners or alternatively, strip curtains which are easy to replace in the case of damage.

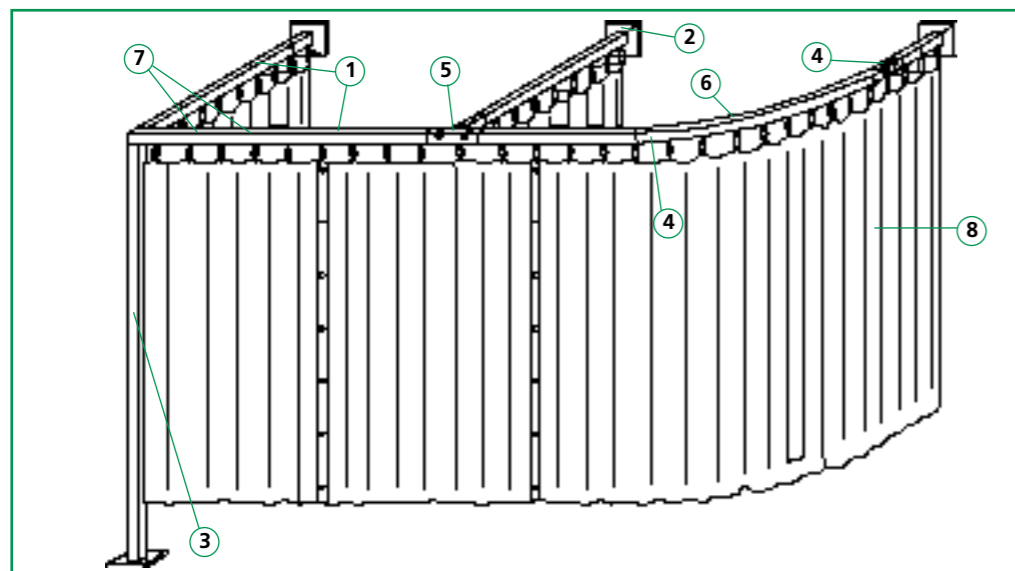

Mobile welding curtain
Welding curtain incl. stand
Dimensions W x H:
1450 x 2000 mm
Available with the following curtains:
Dull green, non-transparent:
Article no.81910150

Orange, transparent:
Article no.81910151



* = Special order item



Migatronik kit
Welding curtains incl. stand.
Measurement W x H: 2000 x 2000 mm. Strip curtains measurement:
W x H x D: 470 x 1600 x 1,0 mm

Available with the following curtains:
Dull green, non-transparent:
Article no.81910189
Bronze, transparent:
Article no.81910188
Orange, transparent:
Article no.81910187

Clear:
Protection against draught and grinding dust

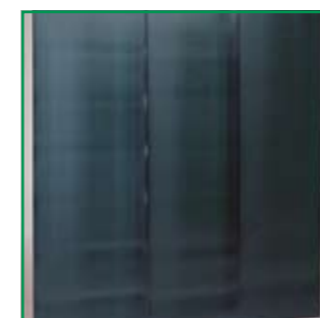
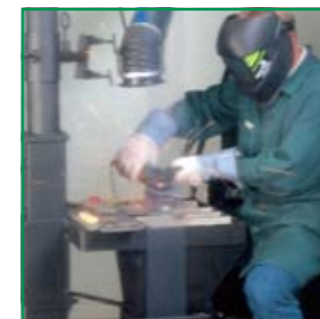

Strip curtains
Migatronik welding curtains with 1.0 mm thick strips. Supplied in boxes of 4. Check dimensions of the strip curtains in the table below and design a booth that suits your requirements.

Large workpieces can easily be passed through the curtains, and in the case of damage it is necessary to replace only the damaged strip(s).

* = Special order item

Orange:
Shielding during arc welding



Hooks for stand
Article no.81910210

Bronze:
Shielding during arc welding

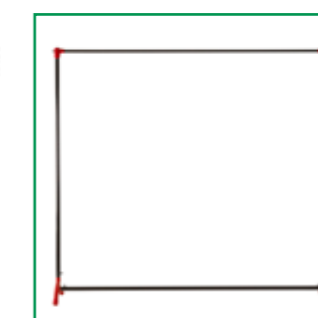

Curtain stand
Curtain stand for Migatronik kit.
Dimension H x W:
2000 x 2000 mm
Article no.81910209

Green (non-transparent):
Shielding during arc welding

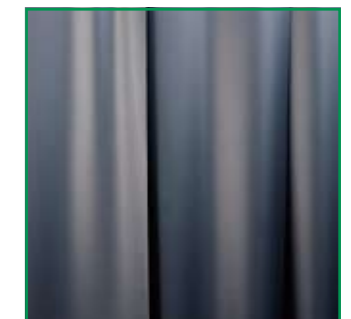

Mobile welding curtain
Mobile welding curtain with 2 pivoting arms allows you to make either a booth or an extended curtain (4050 mm x 2100 mm). The stand is supplied with 1.0 mm thick non-transparent or orange strips.
Non-transparent strips
Article no.81910284
Orange strips
Article no.81910294

Height mm	Width mm	Thickness mm	Number	Dull green	Bronze	Orange (Special order item)
1600	570	1.0	4	81910163	81910169	81910166 *
2000	570	1.0	4	81910165	81910171	81910168 *



Pressure regulators



ARGONEX 30 I.
Article no.81963058



TIGEX I Ar/Mix 30 I.
Article no.81963055



TIGEX II Ar/Mix 30 I.
Article no.81963057



Acetylene
Article no.81963065



Oxygen
Article no.81963066



CARBONEX 30 I.
Article no.81963060



TIGEX I CO2 30 I.
Article no.81963061



Formier 30 I.
Article no.81963067



Formier 30 I.
Article no.81963068



OPTIMATOR Ar/mix
Article no.81963041



OPTIMATOR Ar/H2
Article no.81963042



OPTIMATOR II Ar/mix
Article no.81963043



OPTIMATOR II Ar/H2 *
Article no.81963044



**OPTIMATOR Gas-saver
Ar/mix**
Article no.81963054



**OPTIMATOR Tap unit
1 flowmeter**
Article no.81963045



**Optimotor Gas-saver
For Altop**
Article no.81963316

* = Special order item



Wall fittings
Article no.81963130



Angle piece
Article no.81963131



T-piece
Article no.81963132



Closing regulator
Article no.81963133



Flowmeter pipe, complete
Article no.81963128



Flowmeter pipe, exterior
Article no.81963137



Flowmeter pipe, complete
Article no.81963138



Gas flow gauge
Article no.81010000



Manometer
Optimotor, 3-5 bar
Article no.81963127



Manometer *
Acetylene low pressure
Article no.81963140

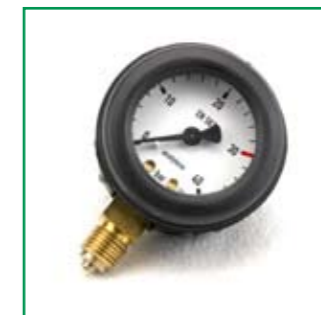

Manometer *
Acetylene high pressure
Article no.81963141



Manometer *
Carbo-/Argonex, Tigex high pressure
Article no.81963144



Manometer *
Carbo-/Argonex, low pressure
Article no.81963145



**Quick-release fitting, male
Gas**
Article no.43120008



**Quick-release fitting, female
For pressure regulator**
Article no.43120026



Flowmeter pipe
Flowmeter pipe with exterior collar
Article no.81963173



Pressure regulators



Gas preheater *
CO₂ W 21.8 x 14.1. 1 x 230V.
Article no.81960048



Disposable non-return valve
Acetylene 3/8" L
Article no.81963121



Disposable non-return valve
Oxygen 3/8 3/8" R
Article no.81963120



Double tap *
Ar/Mix 3/8 H
Article no.81963149

Recyclable non-return valve
(no photo)
Article no. 81963142 *

Recyclable non-return valve
(no photo)
Article no. 81963143 *



Gas welding kit *
Article no.81970002



Argon cylinder CO₂ adjustment
Article no.81961008



Transition nipple
CO₂ cylinder Argon adjustment
Article no.81961007



Cylinder gasket
Ar, CO₂, O₂
Article no.81963129

Cylinder gasket
Acetylene
Article no.81963139*

* = Special order item



Remote controls



Foot switch FTF
Infinitely-variable adjustment of current adjustment range. Adjustment of current and start/stop function. Remote control cable, 8-pole and 6-pole.
Article no.78815010



Foot switch
7-pole aircooled.
Article no.78815016

7-pole watercooled.
Article no.78815015



Remote control FPB
Pulse adjustment, also with pulsing in slope-up and slope-down function. Infinitely-variable adjustment of pulse current and base current. Infinitely-variable setting of pulse time and pause time. 8-pole remote control cable.
Article no.76116380



Remote control FSL
Pocket remote control unit. 8-pole remote control cable.
Article no.76116382

Remote control FSJ
Pocket remote control unit, metal. 8-pole remote control cable.
Article no.76116343

Remote control kit for MWF 1011/21
Article no.78861182



Remote controls for KMX, Flex XMA and Sigma
2 potmeters, 8-pole plug; For MIG/MAG adjustment
Article no.78815028

1 potmeter, 8-pole plug; For MMA adjustment
Article no.78815029

Remote controls for Pi
1 potmeter, 7-pole plug; For MMA adjustment
Article no.78815035

Chemicals



MIG Spray
MIG/MAG spray with propellant gas (propane). Approved for galvanisation without any pre- or post-treatment cleaning. Supplied in 400 ml cans.
Article no.81950009



Cooling liquid
Special eco-friendly cooling liquid for Migatronic's water-cooled welding machines.
5 litre can:
Article no.99290505



Refill
Silicone-free MIG spray refill: 10 litre can.
Article no.81950027
10 litre can for robot.
Article no.81950028



MIG Paste
Welding and protection paste. Protects gas nozzles against slag. Made of purely natural products. Silicone-free. Supplied in 300 g jars.
Article no.81950026



Spray paint
Original Migatronic spray paint
Dark green:
Article no.99311003



Green:
Article no.99311004



Grey:
Article no.99311005

* = Special order item

Tools



Nozzle tongs
Article no.81940028



Nozzle tongs
Ø 12-15 mm.
Article no.81940010



Nozzle tongs
Ø 15-18 mm.
Article no.81940011



Gas nozzle cleaner
Special gas nozzle cleaner with spring blades. Fits all gas nozzles.
Article no.81940012



Chipping hammer
Chipping hammer with metal handle. 430 gm.
Article no.81920003

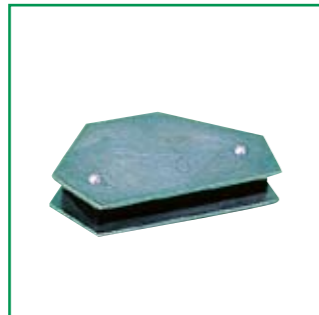

Mitre magnet
Mitre magnet for 30°, 45°, 60°, 75° and 90°. Retaining power 1 x 300 N
Article no.81080003

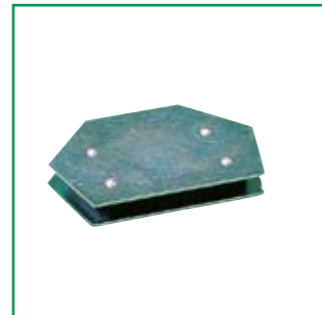

Mitre magnet
Mitre magnet for 30°, 45°, 60°, 75° and 90°. Retaining power 1 x 450 N
Article no.81080005



Body chisel
Standard body chisel. Made in Germany
Article no.81940024



Brush for stainless steel and aluminium, green
Article no.81940020



Marking crayons, oil
Box containing 12 pcs., white
Article no.81010015
Box containing 12 pcs., yellow
Article no.81010016
Box containing 50 pcs., soapstone
Article no.81010017



Mirror
Detachable mirror, 1.5 mm thick.
Article no.81912204

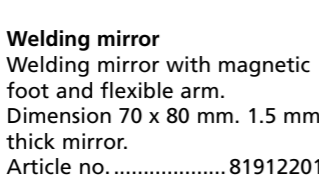

Welding mirror
Welding mirror with magnetic foot and flexible arm. Dimension 70 x 80 mm. 1.5 mm thick mirror.
Article no.81912201

Welding mirror
Fitted on flexible arm and with ball joint. Dimension 70 x 80 mm. 1.5 mm thick mirror.
Article no.81912202



Carbon-arc torch
Carbon-arc torch, K - 4000
Article no.81899001
Carbon-arc electrodes, 6 x 305 mm.
Article no.81899006
Carbon-arc electrodes, 8 x 305 mm.
Article no.81899008
Carbon-arc electrodes, 10 x 305 mm.
Article no.81899010
Carbon-arc electrodes, 13 x 305 mm.
Article no.81899013

Fume extraction



PM 300 mouthpiece *
Rectangular extraction mouthpiece, 300 mm wide, with magnetic foot.
For ø45 extraction hose.
Article no.82031002



TM 200 mouthpiece
Rectangular extraction mouthpiece, 200 mm wide, with magnetic foot.
For ø45 extraction hose.
Article no.82031001

For ø50 extraction hose.
Artikelnr.82031078



TM 80 mouthpiece
Round extraction mouthpiece, ø80 mm with magnetic foot.
For ø45 extraction hose.
Article no.82031003



Flexible extraction hose
Flexible hose by the running metre for MigAir and mouthpiece. Interior ø45 mm.
Article no.92570041



Adaptor *
Article no.82031024



Filter
For MigAir 8841
Article no.82031005



MigAir 1000 *
1 x 230 V = 0.75 kW extraction unit for wall-mounting and the unit includes a wall bracket and motor. Fitted with 3 m extraction arm with knee joint and thus occupying a minimum of space when not in use. Also available with light kit allowing installation of a 12 V bulb in the extraction funnel.
3 x 400 V.
Article no.82031039
1 x 230 V
Article no.82031074



MigAir 841 *
MigAir 841 is equipped with an automatic start/stop function connected to a holder on the extraction unit. Once welding has started, extraction will start. The stop function is adjustable with 5-25 seconds delay so as to ensure that all fume is extracted. At the same time the torch is additionally air cooled. The automatic stop function is energy saving and ensures a longer life of the MigAir 841. Equipped with indicator for replacement of no-touch filter. 220 V.
Article no.82031011

* = Special order item



Automotive equipment



Tool box for Automig
incl. torch holder.
Article no.78861157



Separate torch holder
Article no.78861164



Kit for 230V 10 A auxiliary voltage supply
from three-phase machines.
Article no.78861153



Knob for adjustment of spot and interval welding facilities
Article no.18508004
Knob for adjustment of current
Artikelnr.18508002

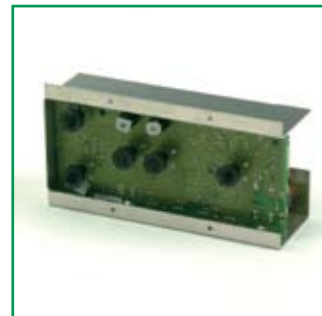

Electronic control box MPS 4TF
with automatic spot welding and interval welding facilities and possibility of using Dialog torch.
Article no.76116982



Electronic control box UPS
without automatic spot welding and interval welding facilities.
Article no.76116984



Pull hammer
Used with pull nails for the repair of minor vehicle body damage.
Article no.81920010



Pull nails and discs
For welding onto the vehicle body and used together with pull hammer.
Pull nails:
Article no.42790011
discs:
Article no.42799020



Torches Automig 98 - 183/223 ML 150 Twist
3 m without remote control
Article no.80197150
ML 150
3 m with remote control
Article no.80196150
ML 150
4 m without remote control
Article no.80197151
ML 150
4 m med fjernregulering
Article no.80196151



Torches Automig 98 - 273 ML 250 Twist
3 m without remote control
Article no.80197250
ML 250
3 m with remote control
Article no.80196250
ML 250
4 m without remote control
Article no.80197251
ML 250
4 m with remote control
Article no.80196251



Torches Automig 1989-98 250 A Twist
ML250 3 m
without remote control
Article no.80197250
ML250 3 m
with remote control
Article no.80196250
ML250 4 m
without remote control
Article no.80197251
ML250 4 m
with remote control
Article no.80196251



Torches Automig until 1989 180/200/250 A
ML 150 B - XR
Article no.80191177



Central connections
Central connection for Automig
Article no.71110111
Central connection for Automig X
Article no.71110114
Central connection for Automig XE
Article no.71110120
Central connection for Compact 120/160C
Article no.71110103



Stainless steel kit for Automig

- 1 pcs. Carbon wire liner with bronze neck liner
- 1 pcs. Wire roll kit 0.8 mm
- 1 pcs. Guide tube for wire liner
- 1 pcs. Argon valve and manometer
- 15 kg 316 LSI 0.8 mm stainless steel wire

Complete kit

- Article no.: 80160707
- Article no.: 73940039
- Article no.: 26310087
- Article no.: 81963058
- Article no.: 81843808
- Article no.: 81100121**



Aluminiums kit for Automig

- 1 pcs. Wire liner
- 1 pcs. Wire rolls kit 1.0 mm
- 1 pcs. Guide tube for wire liner
- 1 pcs. Argon valve and manometer
- 5 pcs. Contact tips
- 6 kg AIMg 5 1.0 mm

Complete kit

- Article no.: 80160711
- Article no.: 73940040
- Article no.: 26310087
- Article no.: 81963058
- Article no.: 80130203
- Article no.: 81846710
- Article no.: 81100120**



Torches Automig XE 1989-98 180/200 A
ML 150 B - XE
Article no.80191178



Small Starter Kit for Automig

- 1 pcs. Hand shield
- 5 kg 0.8 mm mild steel wire
- 1 pcs. 6 kg CO₂ in cylinder
- 1 pcs. CO₂ pressure reducing valve and manometer
- 1 pcs. Distance piece for 5 kg wire reel

Complete kit

- Article no.: 81910144
- Article no.: 81810012
- Article no.: 81710001
- Article no.: 81963060
- Article no.: 26150019
- Article no.: 81100115**



Torches Automig 98 - 183/223 ML 150 C / ZA
4 m without remote control
Article no.80197179



Big Starter Kit for Automig

- 1 pcs. Welding helmet
- 5 kg 0.8 mm mild steel wire
- 1 pcs. 6 kg CO₂ in cylinder
- 1 pcs. CO₂ pressure reducing valve and manometer
- 1 pcs. Distance piece for 5 kg wire reel

Complete kit

- Article no.: 81910090
- Article no.: 81840012
- Article no.: 81710001
- Article no.: 81963060
- Article no.: 26150019
- Article no.: 81910248**

Automotive equipment



Spare parts kit for Automig 183/223 (ML 150)

Swan neck	Number: 1 pcs.	Article no.: 80151202
Gas nozzle	Number: 5 pcs.	Article no.: 80140023
Contact bush	Number: 5 pcs.	Article no.: 80110020
Retaining spring	Number: 5 pcs.	Article no.: 80100021
Contact tip 0.8	Number: 25 pcs.	Article no.: 80130202
Wire liner, blue	Number: 2 pcs.	Article no.: 80160521
Spare parts box	Number: 1 pcs.	Article no.: 81100211
Order form	Number: 1 pcs.	Article no.: 50129160
Complete kit		Article no.: 81100223



Spare parts kit for Automig 273/MIG 305 (ML 250)

Swan neck	Number: 1 pcs.	Article no.: 80151302
Gas nozzle	Number: 5 pcs.	Article no.: 80140601
Contact bush	Number: 5 pcs.	Article no.: 80110601
Retaining spring	Number: 5 pcs.	Article no.: 80100600
Contact tip 0,8	Number: 10 pcs.	Article no.: 80130202
Contact tip 1,0	Number: 10 pcs.	Article no.: 80130203
Wire liner, blue	Number: 2 pcs.	Article no.: 80160521
Spare parts box	Number: 1 pcs.	Article no.: 81100211
Order form	Number: 1 pcs.	Article no.: 50129160
Complete kit		Article no.: 81100224



Supplement to TIG starter kit
1 pcs. Argon in 12 l cylinder (2,4 m³).
Article no.: 81711000

10 kg AlMg5, 2.4 x 1000 mm for aluminium welding rod.
Article no.: 81856724

5 kg Miga KV2 2.5 x 1000 mm for mild steel welding rod.
Article no.: 81850009



Tungsten grinder Green Pointer X2
DK:
Article no.:82036184
Export with Schuko plug
Article no.:82036170



Diamond disc
For Green Pointer X2, ø 40 mm
Article no.:82036171

Trouble-free TIG welding requires a correctly-ground Tungsten electrode. Grind the electrode with a fine-grained diamond disc which is designed for grinding Tungsten electrodes. Grinding method and angle will depend on individual preferences.

For special requests for delivery of Tungsten electrodes in non-standard lengths (or ground electrodes): please contact Migatronic.



Electrode holder
For Green Pointer X2
Article no.:82036172



Filter for Green Pointer X2
Article no.:82036179



Electrode clamps
For Green Pointer X2.
ø 1.0 mm
Article no.:82036173
ø 1.6 mm
Article no.:82036174
ø 2.0 mm
Article no.:82036175
ø 2.4 mm
Article no.:82036176
ø 3.2 mm
Article no.:82036177
ø 4.0 mm
Article no.:82036178



Tungsten recommendations
Article no.:52179133

Diameter x standard length	Red 2% Th Article no.	Green ren Article no.	Black 1% La Article no.	Grey 2% Ce Article no.	Orange 4% Th Article no.	Turquoise WS2 Article no.	Blue 2% La Article no.	Gold 1,5 % La Article no.	Super Blue WS 2 Article no.
1,0 x 175 mm	80360001	80360021	80360041	80360051	80360061		80360091	80361191	80361371
1,6 x 175 mm	80360002	80360022	80360042	80360052	80360062	80360070	80360092	80361192	80361372
2,0 x 175 mm	80360003			80360053	80360063	80360071	80360093	80361193	
2,4 x 175 mm	80360004	80360024	80360043	80360054	80360064	80360072	80360094	80361194	80361374
3,2 x 175 mm	80360006	80360026	80360044	80360055	80360066 *	80360073	80360095	80361195	80361376
4,0 x 175 mm	80360007	80360027	80360045	80360056	80360067 *		80360096	80361196	80361377
4,8 x 175 mm	80360008		80360047					80361197	80361378

* = Special order item

Quick releases



Quick release
Water, ø 6 mm
Article no.43120015



Quick release
Water, ø 6 mm
Article no.43120003



Quick release
Water, SL connector ø 5 mm
Article no.43120007



Quick release
Water with valve ø 6 mm
Article no.43120015



Quick release
Water with valve ø 8 mm
Article no.43120016



Quick release
Water SLST ø 8 mm
Article no.43120017



Quick release
Water with valve ø 6 mm
Article no.43120021

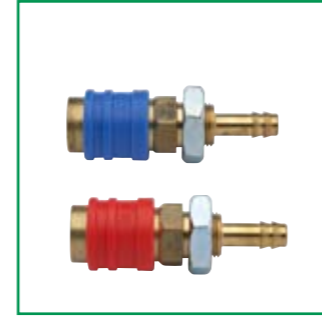

Quick release
Water with valve ø 6 mm
Article no.43129003



Quick release female
For pressure regulators
Article no.43120026



Quick release
Gas, ø 6 mm
Article no.43120008



Quick release
Gas, 1/8"
Article no.43120012



Quick release
Gas, 1/8"
Article no.43120027



Quick release
Water with valve, ø 8 mm
Article no.43120022



Quick release
Gas, ø 6 mm
Article no.43120025



Quick release, plasma
Article no.43120047



Quick release, plasma
Article no.43120048

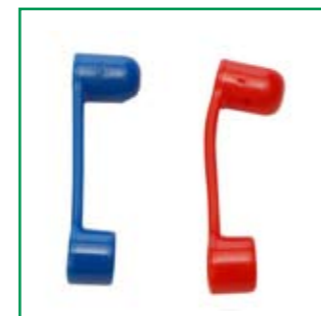

Water stoppers
Ø 9.5 mm for TIG hoses
Blue
Article no.45050339
Red
Article no.45050340



Quick release
Water with valve, ø 8 mm
Article no.43129003



Quick release
Water with valve, ø 8 mm
Article no.43129007



Quick release
Water with valve, ø 8 mm
Article no.43129008

Ø 11.2 mm for MIG hoses
Blue
Artikelnr.45050341
Red
Article no.45050342



Cables/plugs and holders



Myking electrode holder
Insulating rubber jacket.
2 settings with welding angle 45° or 90°. Optimum current transfer. Screwed type for optimum fixing of the electrode. 200 A. Article no.....80550010
450 A. Article no.....80550009
600 A. Article no.....80550008



Separate head for Myking
45°/90°. 200 A.
Article no.80550027
45°/90°. 450 og 600 A.
Article no.80550028

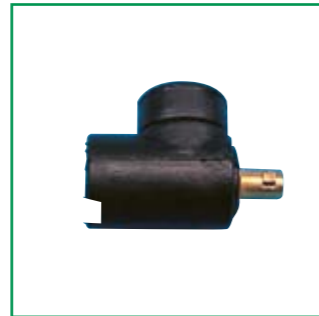

Distributor socket T-piece
Used for double connections.
Cable 70
Article no.18120050

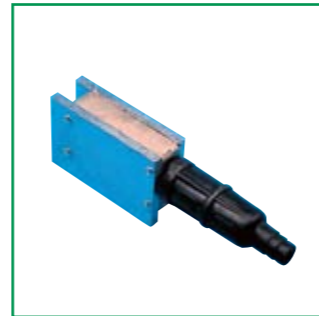

Magnetic earth clamp
200 A. Article no.....80560013
400 A. Article no.....80560014
600 A. Article no.....80560015

Electrode holder
"Alligator clip"
300 A. Article no.....80550037
400 A. Article no.....80550035
600 A. Article no.....80550036



Handle for MYKING 2, 450 A.
Article no.80550032

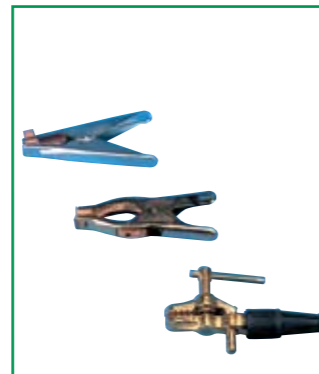

Earth clamp
250 A. Article no.....80560010
400 A. Article no.....80560011
500 A. Article no.....80560012

Spring earth clamp
200 A nev. 200
Article no.80560001

300 A nev. 350
Article no.80560002

Screw-on earth clamp
600 A.
Article no.80560009



Earth clamp, 600 A
Article no.80560022

Dinse connection plug, male
0-25 mm². Ø 10.
Article no.18120006
35 -50 mm². Ø 13.
Article no.18120002
50 - 70 mm². Ø 13.
Article no.18120003
70 - 95 mm². Ø 13.
Article no.18120004

Dinse connection socket, female
10-25 mm². Ø 10.
Article no.18110001
35 -50 mm². Ø 13.
Article no.18110002
70 - 95 mm². Ø 13.
Article no.18110003

Extension socket, female
10-25 mm². Ø 10.
Article no.18110101
35 -50 mm². Ø 13.
Article no.18110102
50 - 70 mm². Ø 13.
Article no.18110103



Bush for cable. 450 A/600 A
Article no.25440003



Bush for 9 mm cable. 200 A
Article no.80550030

Cables for remote control units	6 poles	8 poles	19 poles
Length	Article no.	Article no.	Article no.
1 m interconnection for TIG unit	74341000	74340000	x
3 m cable	x	x	x
5 m cable	74341003	74340003	74341010
6 m cable	x	x	x
10 m cable	74341001	74340001	74341011
15 m cable	x	x	74341012
20 m cable	74341002	74340002	74341013

Approved rubber electrode cables: acid and oil resistant

Square mm	16	25	35	50	70
Length					
3 m	80511603	80512503	80513503	80515003	80517003
5 m	80511605	80512505	80513505	80515005	80517005
10 m	80511610	80512510	80513510	80515010	80517010
15 m	80511615	80512515	80513515	80515015	80517015
> 15 m	80511690	80512590	80513590	80515090	80517090

Fitted with electrode holder and Dinse connection plug

Approved rubber electrode cables: acid and oil resistant

Square mm	16	25	35	50	70	95
Length						
3 m	80501603	80502503	80503503	80505003	80507003	80509503
3,5 m	80571002	(For Automig without excl. Dinse connection.)				
5 m	80501605	80502505	80503505	80505005	80507005	80509505
10 m	80501610	80502510	80503510	80505010	80507010	80509510
15 m	80501615	80502515	80503515	80505015	80507015	80509515
> 15 m	80501690	80502590	80503590	80505090	80507090	80509590

Fitted with earth clamp and Dinse connection plug

Approved extension cables for electrode cables and earth cables

Square mm	16	25	35	50	70
Length					
3 m		80522503	80523503	80525003	80527003
5 m	80521605	80522505	80523505	80525005	80527005
10 m	80521610	80522510	80523510	80525010	80527010
15 m	80521615	80522515	80523515	80525015	80527015
> 15 m	80521690	80522590	80523590	80525090	80527090

Fitted with Dinse connection plug and socket

Welding cables
High-quality rubber welding cables in accordance with International Standard approvals for welding. Copper (item no. is for 1 metre)

16 mm².
Article no.92340016

25 mm².
Article no.92340025

35 mm².
Article no.92340035

50 mm².
Article no.92340050

70 mm².
Article no.92340070

95 mm².
Article no.92340095

Please contact us if you require our assistance in calculating dimensions and lengths of cables.



Separate screw for 200 A cable
10 x 8
Article no.80550029

Separate screw for 450 A cable
10 x 10
Article no.80550031

Separate screw for 450 A cable
12 x 12
Article no.40511212

Recommended dimensions/lengths of welding cables
Max. 20 m length for ordinary welding

Max. duty cycle in A							
Copper	100%	60%	35%	Copper	100%	60%	35%
16 mm ²	130	145	165	50 mm ²	265	315	380
25 mm ²	170	200	240	70 mm ²	325	395	475
35 mm ²	210	245	295	95 mm ²	390	475	580
				120 mm ²	460	570	700



Multiplug 6-pole

1. Multiplug, female:
Article no.17200001
2. Multiplug, male:
Article no.17210001
3. Multiplug housing (plastic) for fitting to machine:
Article no.18200002
4. Cover for multiplug (plastic):
Article no.18200004
5. Multiplug housing (metal) for fitting to hose:
Article no.18200101
6. Multiplug housing (metal) for fitting to machine:
Article no.18200102
7. Extension for multiplug housing (metal) for fitting to hose:
Article no.18200103
8. Junction box (metal):
Article no.74348002

Multiplug 8-pole

9. Multiplug, female:
Article no.17200023
10. Multiplug, male:
Article no.17210024
11. Adapter (metal):
Article no.74348001
12. Multiplug, female:
Article no.17200026
13. Multiplug, male:
Article no.17210026
14. Adapter (metal):
Article no.74348003

Multiplug 19-pole



Multiplug 4-pole

15. Multiplug, female:
Article no.17200030
16. Multiplug, male:
Article no.17210030

Multiplug 7-pole

17. Multiplug, female:
Article no.17200056
18. Multiplug, male:
Article no.17210057



Spare parts box MIG/MAG

Spare parts box with storage compartments. Excl. spare parts.
Dimensions H x L x W: 57 x 340 x 265 mm
Article no.81100211

Order form MIG/MAG

Order form consisting of: MIG/MAG front page, ML/MV blank page, ML 130, ML 150, ML 240, ML 250, ML 300/360, MV 240, MV 450/550
Article no.50129100



Spare parts box Zeta

Complete with all spare parts
Article no.81100239



Spare parts box TIG

Spare parts box with storage compartments. Excl. spare parts.
Dimensions H x L x W: 57 x 340 x 265 mm
Article no.11100210

Order form TIG

Order form consisting of: TIG front page, TIG blank page, TIG 100 valve, TIG 100, TIG 200/260, TIG 300, TIG 400, TIG 500
Article no.50129300



TIG torch brochure

Article no.52125001

MIG torch brochure

Article no.52125000

Electrode ovens



Storage cabinet for electrodes ES 210 *

This cabinet is designed for storage of electrodes but is also suitable for drying at low and medium temperatures. A thermostat provides infinite adjustment of temperature up to 300°C. Shelf units consist of 3 shelves removable as 1 unit.

Primary voltage	110/220 V
Power	1000 W
Primary current	4,5 A
Operating temperature	50 - 300°C

Dimensions, mm W x L x H:

Electrode compartment	460 x 500 x 520
Exterior dimension	560 x 640 x 740
Electrode capacity	210 kg
Net weight	50 kg

Article no.81795003



Wire adaptor

Used when changing from plastic reels to metal reels.
Article no.81899017



Storage cabinet for electrodes and powders ES 260 *

Outdoor and indoor portable storage cabinet for electrodes and powders and drying at low or medium temperatures. An infinitely adjustable (up to 300°C) thermostat ensures a constant temperature inside the cabinet. If storage of electrodes in original packing is required, the cabinet can be fitted with a safety thermostat keeping the temperature below 70°C. The cabinet can be transported either by crane or fork-lift truck.

Primary voltage	220 V
Power	2300 W
Primary current	10 A
Operating temperature up to	300°C

Dimensions, mm W x L x H:

Electrode compartment	500 x 500 x 750
Exterior dimension	640 x 640 x 775
Electrode capacity	260 kg
Net weight	110 kg

Article no.81795004



Adaptor for 5 kg reel

Used together with 5 kg/D200 reels.
Article no.45050333



Electrode oven for electrodes and powders with control box ETS 260 *

This cabinet is designed for baking electrodes and powders. The drying temperature is infinitely adjustable up to 500°C and the set temperature is maintained by a high-quality thermostat. The thermostat is fitted with a thermometer for visual control. The shelves are designed to provide air circulation within the cabinet so as to ensure an even temperature throughout the oven. A screen plate protects against radiated heat.

ETS 260 has a timer facility for drying time and can be set at different periods up to 60 hours. The control box can be ordered separately and is easily fitted onto the ETS 260 which thus becomes an ETS 260.

Primary voltage	220/380 V
Power	2300 W
Primary current	10/6 A
Operating temperature up to	500°C

Dimensions, mm W x L x H:

Electrode compartment	500 x 500 x 750
Exterior dimension	640 x 640 x 980
Electrode capacity	260 kg
Net weight	120 kg

Control box *:

Article no.81795006



Storage cabinet RTS 270 for flux-cored wires *

Cabinet designed for storage of flux-cored wires on reels. The drying temperature is infinitely variable and is thermostatically controlled within the range of 20-50°C. The cabinet will hold 18" and 12" wire reels and can be moved fully-loaded by crane or fork-lift truck.

Primary voltage	220 V
Power	500 W
Primary current	2.3 A
Operating temperature	20 - 50°C

Dimensions, mm:

W x L x H:	910 x 510 x 1500
Capacity	270 kg
Net weight	130 kg

Article no.81795007



Green Dryer heat-insulated box Red *

Article no.81795000

* = Special order item

